

ambient temperature photomultiplier housings

QL30, B2, SWH series datasheet

A range of housings is available for use with most photomultipliers up to 51mm diameter, including 30mm side window types. They offer:

- a light-tight enclosure including socket, voltage divider and connectors
- electrostatic and magnetic shielding
- high quality insulators and components to ensure optimum performance

The socket and voltage divider in these housing are chosen to suit the particular pmt being used, which must be specified when ordering. Unless otherwise stated, or requested, the voltage divider will have the standard configuration indicated in the corresponding pmt data sheet, and the value of 'R' will be 330kΩ

The default HV polarity is negative, so that the output is suitable for analogue or pulsed signal applications. However, for applications where the lowest noise is important it is recommended that positive HV be used. In this latter case, internal 100kΩ anode load resistor is incorporated and the signal taken out via a coupling capacitor. This configuration is only suitable for pulsed applications, such as photon counting.

Although the housings are supplied configured for a particular pmt type, different pmt types of the same size but with different pin connections can be accommodated by ordering an additional base assembly. Please note that some pmt types may also require a long barrel.

The QL30 series is suitable for photomultipliers up to 30mm diameter and the B2 series for diameters up to 51mm. B2 series housing can be supplied incorporating gating circuits or other electronics.

Housings are available with or without front mounting flange. RFI shielded versions are available for use in noisy environments and/or for very low signal conditions.

1 QL30 series

The QL30 housing series is designed for use with end-window photomultipliers, of 30mm diameter.

2 QL30 features

- internally threaded front end
- combined electrostatic and magnetic shielding
- quick-release base assembly
- flanged version, QL30F, with integral 'O' ring, and light-tight seal
- the QL30FV version includes vacuum adaptors for coupling to vacuum systems (the vacuum ultra violet wavelength is below 190 nm, the transmission cut-off of air)



3 QL30 specification

signal connector	BNC
HV connector	MHV (SHV optional)
divider R value	330kΩ (other values available)
HV polarity	- HV (+ve optional) (power supply can be integrated)
weight	260g

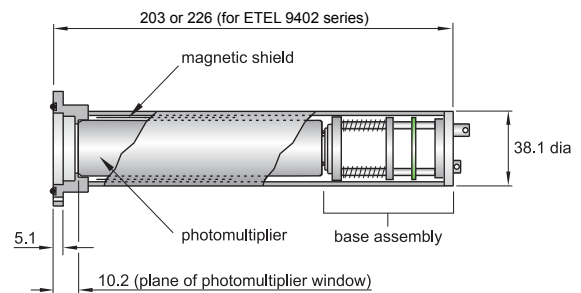

all dimensions in mm

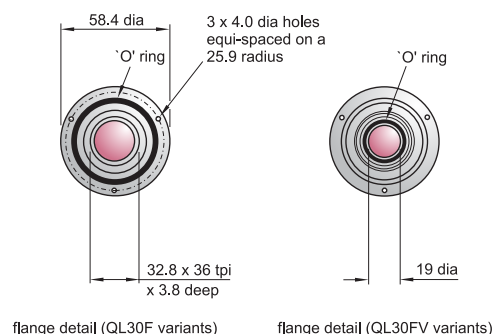

all dimensions in mm

1 B2 series

The B2 housing series is designed for use with end-window pmts, of 51 mm diameter, or smaller when ordered with adaptors. The long barrel option is necessary for pmts having a length of 155 mm or longer. Special versions are available for use with the ETEL 9422 series.

2 B2 features

- accommodates 30, 38 or 51 mm diameter end-window photomultipliers
- flanged version, B2F, with integral 'O' ring, and light-tight seal
- the housing will accept 52.25 mm diameter filters of up to 2.5 mm thickness
- B2FV versions include vacuum adaptors for use in the VUV (the vacuum ultra violet wavelength is below 190 nm, the transmission cut-off of air)

3 B2 specification

signal connector	BNC
HV connector	MHV (SHV optional)
divider R value	330kΩ (other values available)
HV polarity	-HV (+ve optional)
weight	1200g

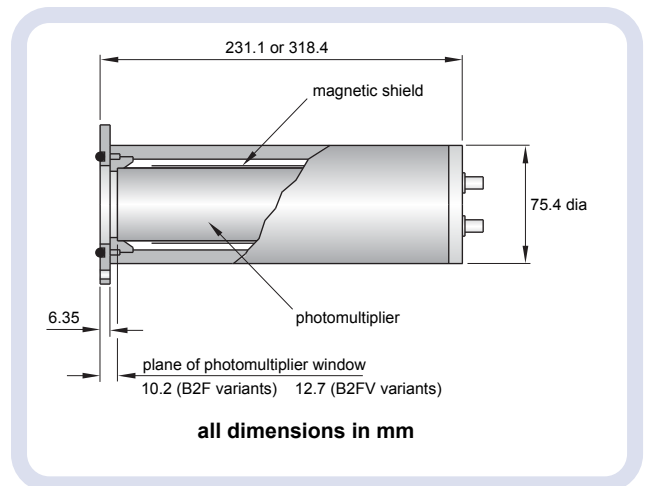

1 SWH series

The SWH series is designed for use with 30 mm side-window pmts.

2 SWH features

- hard nickel plated finish
- electromagnetically shielded socket assembly
- optional version with mu-metal* shutter
- optional filter holder accepting 2 mm x 32.5 mm diameter filters

* mumetal is a registered trademark of Magnetic Shield Corporation

3 SWH specification

signal connector	BNC
HV connector	MHV (SHV optional)
divider R value	100kΩ (other values available)
HV polarity	- HV (+ve optional)
weight	420g

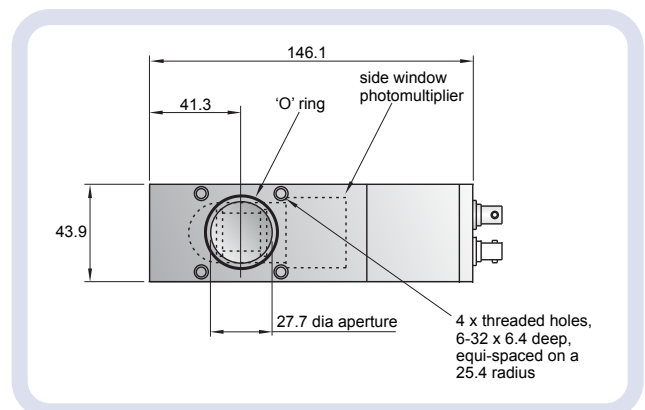
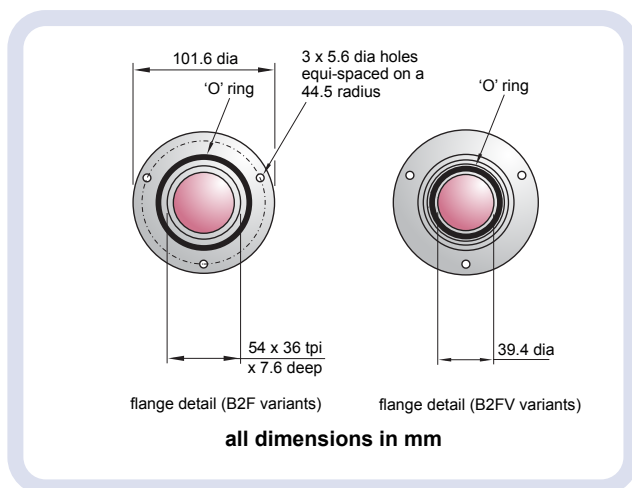

ET Enterprises Limited
45 Riverside Way
Uxbridge UB8 2YF
United Kingdom
tel: +44 (0) 1895 200880
fax: +44 (0) 1895 270873
e-mail: sales@et-enterprises.com
web site: www.et-enterprises.com

ADIT Electron Tubes
300 Crane Street
Sweetwater TX 79556 USA
tel: (325) 235 1418
toll free: (800) 399 4557
fax: (325) 235 2872
e-mail: sales@electron tubes.com
web site: www.electrontubes.com

an ISO 9001 and ISO 14001 registered company

The company reserves the right to modify these designs and specifications without notice. Developmental devices are intended for evaluation and no obligation is assumed for future manufacture. While every effort is made to ensure accuracy of published information the company cannot be held responsible for errors or consequences arising therefrom.

ET Enterprises
electron tubes

© ET Enterprises Ltd, 2015
DS_QL30 series Issue 1 (08/10/15)