

photomultiplier voltage divider

C647 series data sheet

1 description

Voltage dividers provide the voltage distribution required to operate a photomultiplier.

The C647 series of voltage dividers is designed for 52 mm diameter, 10 stage linear focused and venetian blind dynode photomultiplier tubes. Built onto an epoxy glass circuit board using a combination of surface mount and conventional components, the C647 series covers a range of applications with the following variants:

- C647A uniform voltage divider for general purpose applications
- C647B tapered distribution for pulse light applications
- C647C uniform distribution with 150 V Zener diode k-d₁
- C647D tapered distribution for pulsed light applications with 150 V Zener diode k-d₁
- C647E standard distribution for venetian blind pmts
- C647F standard distribution for venetian blind pmts with 150V Zener diode k-d₁

C647 voltage dividers are supplied mounted on a B19A socket, either unflanged or flanged. It is soldered to the circuit board for direct connection to the photomultiplier. Conformal coating is available on request.

2 applications

The C647 series is suitable for the following applications using 52 mm diameter, 10 stage photomultiplier tubes:

- analogue
- pulsed light
- photon counting

3 features

- compact
- low cost
- high reliability
- positive or negative high voltage
- ac/dc coupled versions of the negative option
- tapered distribution option for pulsed applications

4 specifications

operating position	any
weight:	
with socket, no flange	23g
with socket and flange	28g
resistor tolerances	±2%
operating temperature range	-25° C to + 70° C
humidity (non-condensing)	93% RH maximum at 30° C
atmospheric pressure range	100 kPa (1 bar) to 68 kPa (0.68 bar)
applied voltage	2000 V maximum (subject to not exceeding max. rating of photomultiplier tube)



Examples of the ET Enterprises range of Voltage Dividers

5 outline drawings (mm)

mounting option S (ie. C647AS)

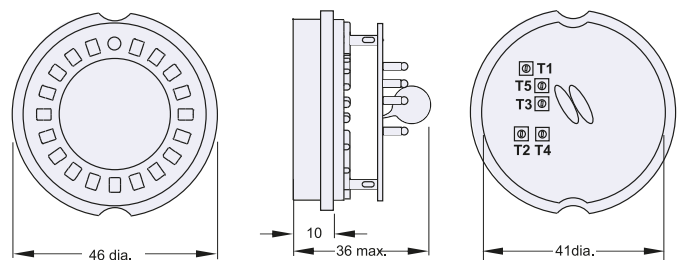

mounting option F (ie. C647AF)

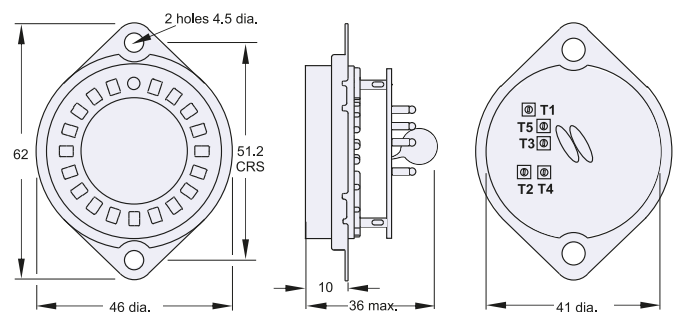

Terminal posts T1 to T4 are provided for solder connection to high voltage power supply and signal cables. Cables with or without connectors, are available at additional cost. It is recommended that any electromagnetic screening around the photomultiplier tube is connected to photocathode potential via terminal post T5.

6 schematic diagram

Shown for +ve, ac coupled

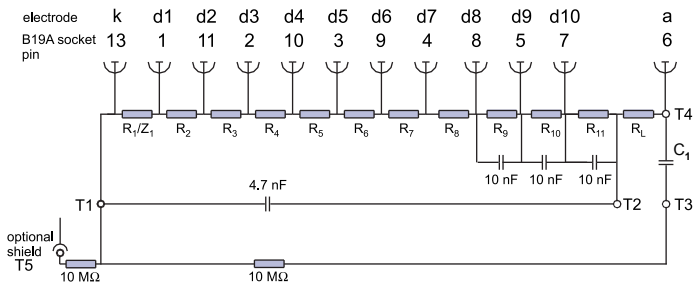

7 configuration

	application example	Connections				config. suffix
		T1	T2	T3	T4	
Positive HV, ac coupled	Scintillation counters	0 V ground	+HV	Signal output	-	P
Negative HV, dc coupled, no anode load	Electrometers	-HV	0 V ground	-	Signal output	N1
Negative HV, dc coupled, anode load $R_L = 100 \text{ k}^*$	Photon counting, high energy physics	-HV	0 V ground	-	Signal output	N2

* C_1 is omitted for negative HV.

8 series options

	R_1/Z_1^*	R_2	R_7	R_8	R_9	R_{10}	R_{11}
C647A	2R	R	R	R	R	R	R
C647B	2R	R	R	2R	3R	4R	3R
C647C	150 V	R	R	R	R	R	R
C647D	150 V	R	R	2R	3R	4R	3R
C647E	2R	R	R	R	R	2R	R
C647F	150 V	R	R	R	R	2R	R

*The C647C, C647D and C647F have a 150 V Zener diode Z_1 to maintain the optimum k- d_1 potential in cases where photo-multipliers are operated over a wide range of gains.

9 ordering information

In order to define the voltage divider you require, please select a variant, mounting option and configuration from the list below:

C647

variants

A, B, C, D, E, F see section 8 for different voltage divider options

mounting options

S voltage divider with B19A socket, no flange

F voltage divider with B19A socket, with flange

configuration

P positive HV, ac coupled

N1 negative HV, dc coupled, no anode load

N2 negative HV, dc coupled, anode load, $R_L = 100 \text{ k}$

Example

C647CFN1: C647 with tapered distribution for pulsed applications, fitted with a B19A socket, with flange, configured for negative HV, dc coupled, no anode load.

As standard $R=330 \text{ k}$. Special versions can be made with values in the range of $100 \text{ k}\Omega$ to $10 \text{ M}\Omega$. Please contact us to discuss your requirements. More information is available: refer to Technical Reprint RP069 available on our website at www.et-enterprises.com

10 warning

The high voltage used by these products may present an electrical shock hazard. They should be installed and serviced only by qualified personnel and operated in accordance with the specified ratings.